



Eppendorf Repeater[®] Pro

Instruction Manual · Manual de Instrucciones

eppendorf

See chapter 4 / ver apartado 4

	Vol.	Max. No. Steps/ Nº máx. pasos	Systematic error/ Error sistemático (Inaccuracy/Incorreción)		Random error/ Error accidental (Imprecision/Imprecisión; CV)	
			1/10 max. Vol./ 1/10 vol. máx.	max. Vol./ Vol. máx.	1/10 max. Vol./ 1/10 vol. máx.	max. Vol./ Vol. máx.
0.1 mL Combitep	1.0, 1.2, 1.4,	100	± 1.0 %	± 1.0 %	≤ 2.5 %	≤ 0.5 %
0.2 mL Combitep	2.0, 2.4, 2.8,	100	± 1.0 %	± 1.0 %	≤ 1.5 %	≤ 0.5 %
0.5 mL Combitep	5, 6, 7,	100	± 0.9 %	± 0.9 %	≤ 0.8 %	≤ 0.3 %
1.0 mL Combitep	10, 12, 14,	100	± 0.9 %	± 0.6 %	≤ 0.55 %	≤ 0.2 %
2.5 mL Combitep	25, 30, 35,	100	± 0.8 %	± 0.5 %	≤ 0.45 %	≤ 0.15 %
5.0 mL Combitep	50, 60, 70,	100	± 0.8 %	± 0.5 %	≤ 0.35 %	≤ 0.15 %
10.0 mL Combitep	0.10, 0.12, 0.14,	100	± 0.5 %	± 0.4 %	≤ 0.25 %	≤ 0.15 %
25.0 mL Combitep	0.25, 0.3, 0.35	100	± 0.3 %	± 0.3 %	≤ 0.25 %	≤ 0.15 %
50.0 mL Combitep	0.5, 0.6, 0.7,	100	± 0.3 %	± 0.3 %	≤ 0.25 %	≤ 0.15 %

1	Operating controls	4
2	Overview of display and keypad	5
3	Applicational limitations and safety precautions	6
4	Technical data	7
5	Delivery package	7
6	Switching on the Repeater Pro	8
7	Zero Position	9
8	Attaching / ejecting a Combitips® plus	10
9	Functions of the Repeater® Pro	11
9.1	Programming and executing functions	11
9.2	Dispensing: Function "d"	12
9.3	Automatic dispensing: Function "Ad"	14
9.4	Pipetting: Function "P"	16
9.5	Speed of piston movement	18
9.6	Stop	19
9.7	Storing and calling up the dispensing values	19
9.8	Combitip recognition	20
10	Useful information	21
10.1	Remaining stroke	21
10.2	Relaxation stroke	21
10.3	Free-jet dispensing	21
11	Charging the Repeater® Pro	22
11.1	Charging stand	22
11.2	LobAt	22
11.3	Battery set capacity	22
11.4	Changing the battery set	22
12	Maintenance	23
13	Troubleshooting	23
14	Ordering information	24

1 Operating controls

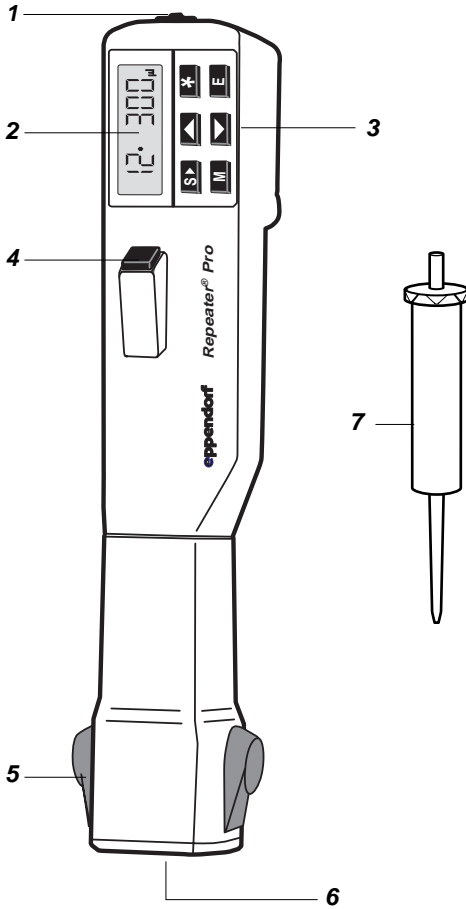

1 ON/OFF switch
(To switch on the pipette, push slide to the right, see Section 6, Fig. 3).

2 Display

3 Keypad

4 Start button

5 Eject buttons

6 Combitip mounting

7 Combitip® plus

The battery set compartment is located behind the control panel at the rear of the housing.

Fig. 1

2 Overview of display and keypad

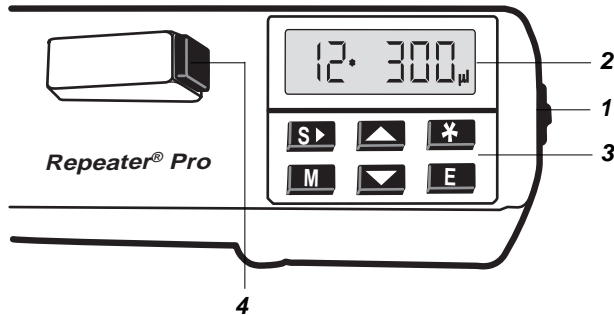
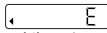



Fig. 2





(Enter) This key is used to confirm all programming processes. It simultaneously serves as a Reset key to interrupt dispensing in the modes Dispensing **d** and Automatic dispensing **Ad** prematurely.

- Hold the Repeater Pro over a test tube.
- Press the Enter key.  appears in display (2).
- Press the Start button (4) twice, the liquid is dispensed.



(Mode) Pressing this key makes it possible to select between Dispensing **d**, Automatic dispensing **Ad** and Pipetting **P** modes. Selection is confirmed with the Enter key .



After selecting the desired mode with the  key, the last volume set appears in the display. Pressing this key activates the dispensing values display which can then be altered using the arrow keys. Selection is confirmed with the Enter key .



The arrow keys are for altering dispensing volume, the number of steps for dispensing and speed. The selection is confirmed with the Enter key .



(Speed) After this key has been pressed, the speed of aspiration and dispensing of the liquid can be set in 5 steps. (5 = the most rapid movement) Selection is confirmed with the Enter key .

3 Applicational limitations and safety precautions

The Repeater Pro can be used to dispense liquid with a viscosity up to that of moderately heavy mineral oils (400 Pa/sec with Combitip[®] plus ≤ 10.0 mL).

The technical data is based on the use of degassed distilled water (see Section 4).

When liquids with a high vapor pressure (e.g. hexane) are dispensed, it is advisable to saturate the air bubble in the Combitip plus with the vapor pressure by aspirating and dispensing liquid several times.

Once the Combitip plus has aspirated liquid, a relaxation stroke needs to be executed before the first dispensing. This **relaxation stroke** is performed by the Repeater Pro automatically (exception: following **StOP**, see Section 9.6)

Caution: Do not remove the Repeater Pro from the liquid prematurely during automatic execution of the relaxation stroke to avoid uncontrolled dispensing of liquid.

Please note that even brief contact with the Start button may trigger a dispensing.

Handle the device with care when dispensing toxic liquids or those containing pathogens (use the charging stand for storage during pauses in work) and maintain a safe working environment (flue, laboratory which conforms to the appropriate safety class).

Extensive instructions on handling germs or biological material are laid down in national and international regulations.

In order to end dispensing in Dispensing **d** and Automatic dispensing **Ad** modes prematurely (Reset), press the Enter key.  appears in the display.

The remaining liquid is dispensed if the Start button is pressed twice.

Caution: The charging stand may only be used with the transformer contained in the delivery package. We do not honor any warranty or accept any liability for damage resulting from the use of other transformers.

4 Technical data / 5 Delivery package

4 Technical data

Details of the inaccuracy and imprecision of the Repeater Pro can be found on the cover at the front of this manual. The abbreviations used there are as follows:

Vol.	= volume
Max. No.Steps	= maximum number of dispensing steps with one Combitip filling
1/10 max.Vol.	= 1/10 of maximum volume (max.Vol)

Test conditions to DIN 12650

and ISO 8655; liquid:

double-distilled water, degassed to DAB

Test temperature:

15 – 30 °C ± 0.5 °C constant,
with original Eppendorf Combitips plus.

Mains supply for charging station:

120 V / 60 Hz

Power consumption of charging station:

1.8 VA

The right to make technical modifications is reserved!

5 Delivery packages

- 1 Repeater Pro
- 1 Charging stand (pipette stand)
- 1 Transformer
- 1 Instruction manual
- 1 Combitip plus

6 Switching on the Repeater Pro

6



Caution: Charge the device before using it for the first time (see Section 11).

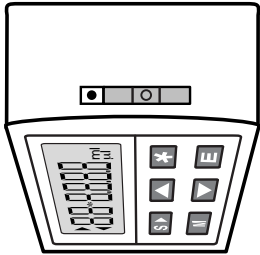

- Push the red slide switch to the right.



- "E" appears in the display.

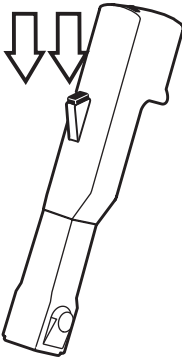

- Press the Start button twice. The motor moves the piston mounting right down to the **Zero Position**.
- The Repeater Pro no longer needs to be switched off (see Section 11.3).
- "tiP" appears in the display. A Combitip plus can now be attached.

Fig. 3

7 Zero Position

Programming of the Repeater Pro and attachment/ejection of Combitips plus are possible only if the Repeater Pro is in the Zero Position. The piston of an attached Combitip is then in the lowest position. If a Combitip has not yet been attached, "tiP" appears in the display.

It is possible to move to the **Zero Position** at any time when the motor is at a standstill (Fig. 4):



- Press the **E** key.



- **E** appears in the display.

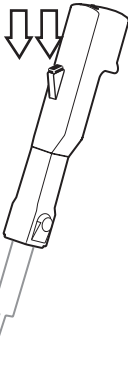

- Press the Start button twice.
The last function programmed for that Combitip size appears in the display, marked by an abbreviation, e.g. **d**.

Fig. 4

8 Attaching / ejecting a Combitip plus

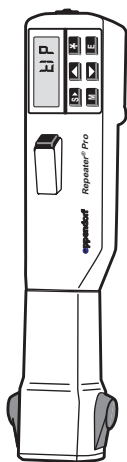

Fig. 5a

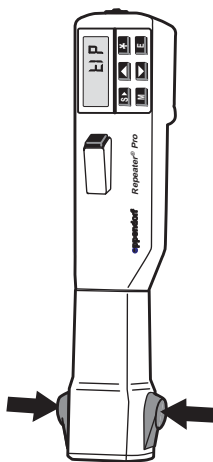

Fig. 5b

Attaching the Combitip plus (Abb. 5a):

- With the piston end facing forwards, push the Combitip up into the piston mounting until it clicks into place. Do **not** press the eject buttons during this process.
- After the Combitip has been attached, the function which was last called up and programmed for this Combitip size appears in the display. The function can be executed immediately.

Ejecting the Combitip plus (Fig. 5b)

- Move the Repeater Pro into the **Zero Position** (see Section 7).
- Press both blue eject buttons on the piston mounting simultaneously. The Combitip drops out of the piston mounting. "tiP" appears in the display.

9 Functions of the Repeater Pro

Dispensing "d":	Multiple dispensing of a partial volume from the Combitip plus. Each dispensing of the liquid is effected by a single press of the Start button.
Automatic dispensing "Ad":	As for dispensing, except that each dispensing is triggered automatically at intervals as long as the Start button is held down. The time interval between dispensings is freely selectable (between 0.1 and 1.0 seconds).
Pipetting "P":	Simple transfer of a volume of liquid using the Combitip plus.

9.1 Programming and executing functions

Repeater Pro in **Zero Position**, desired Combitip is attached (see Sections 7 and 8). If a new function is to be selected, proceed as follows:

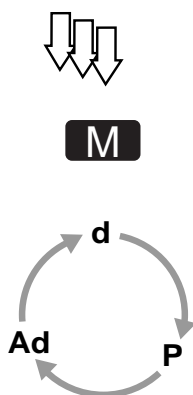

Fig. 6

- Press the **M** key repeatedly until the function symbol **d**, **P** or **Ad** appears in the display.

- Press **E**:
to select the new function. It can be executed immediately or after new dispensing values have been programmed.

9 Functions of the Repeater Pro

9.2 Dispensing: Function "d"

Key sequence

M

- Select Function **d** and confirm with **E**.

Display

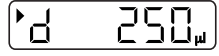

- Repeater Pro is ready to aspirate liquid. Most recently set volume appears in the display.

***** or

- to activate the dispensing volume.

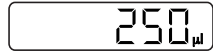

- To set the new dispensing volume desired.

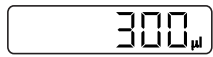

E

- To confirm the entry.

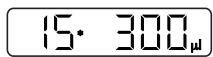

- To display the repeat number (maximum possible number/ number most recently set).

- To set the new repeat number.

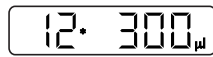

E

- To confirm the entry.

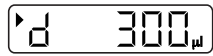

- The Repeater Pro is now ready to dispense 12 x 300 µL.

Caution: The repeat number 100 appears in the display as 00!

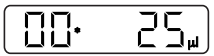

e.g. dispensing 100 x 25 µL from a 2.5 mL Combitip.

9 Functions of the Repeater Pro

Executing the Dispensing function with the Repeater Pro:

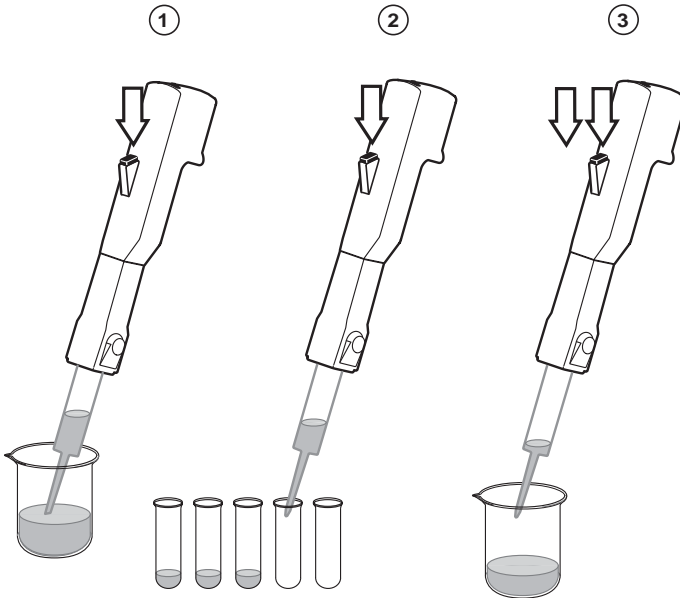

Fig. 7

- 1) Press the Start button briefly with the Combitip in the liquid to aspirate liquid.
- 2) Press the Start button briefly to dispense liquid.
- 3) After the last volume has been dispensed, press the Start button briefly twice: the remaining stroke volume is then dispensed (see Section 10.1).

The dispensing cycle can be repeated immediately.



9 Functions of the Repeater Pro

9.3 Automatic dispensing: Function "Ad"

Key sequence

- M** – Select Function **Ad** and confirm with **E**.

Keypad sequence as for Dispensing, Function **d**, but **additionally, after repeat number has been set:**

-   – To set the new time interval.

- E** – To confirm the entry.

Display



- The time interval which was last set between two automatic dispensings appears in the display (0.1 to 1 sec, in increments of 0.1 sec)

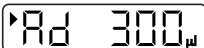

-  – The Repeater Pro is now ready to dispense 12 x 300 µL automatically.

9 Functions of the Repeater Pro

Executing the automatic dispensing function with the Repeater Pro

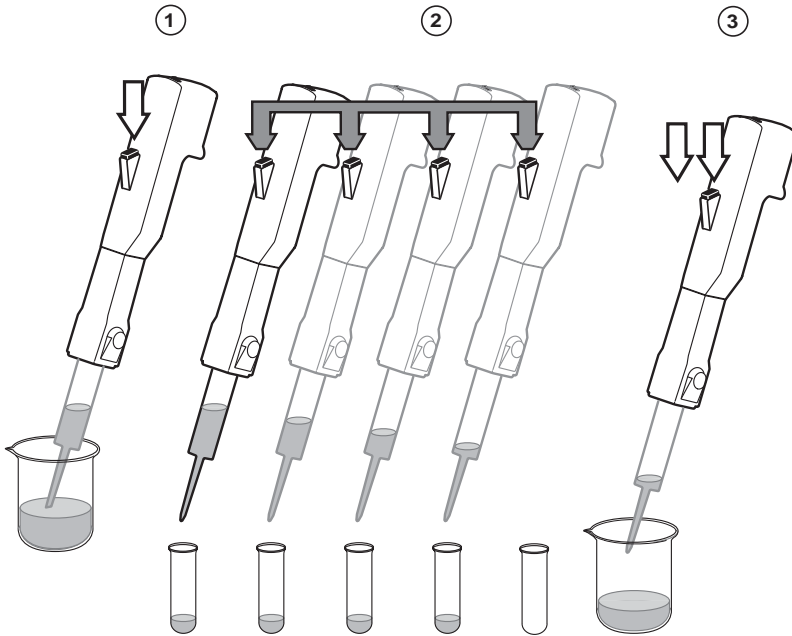

Fig. 8

- 1) Press the Start button briefly to aspirate liquid.
- 2) The Start button is held down; dispensing occurs automatically at the set time interval. Automatic dispensing is interrupted when the button is released and continues when the button is held down again.

Individual dispensings are also possible by pressing the Start button briefly.



- 3) After the last dispensing volume has been dispensed, press the Start button briefly twice to dispense the remaining stroke volume (see Section 10.1).



9 Functions of the Repeater Pro

9.4 Pipetting: Function "P"

Key sequence

M – Select Function **P** and confirm with **E**.

***** or   – To activate dispensing volume.

  – To set the new pipetting volume.

E – To confirm the function.

Display

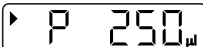

► P 250_µ

– Repeater Pro is ready to aspirate liquid. The most recently set volume appears in the display.



250_µ

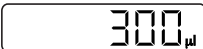

300_µ

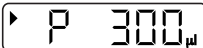

► P 300_µ

– The Repeater Pro is now ready to pipette 300 µL.

9 Functions of the Repeater Pro

Executing the pipetting function with the Repeater Pro

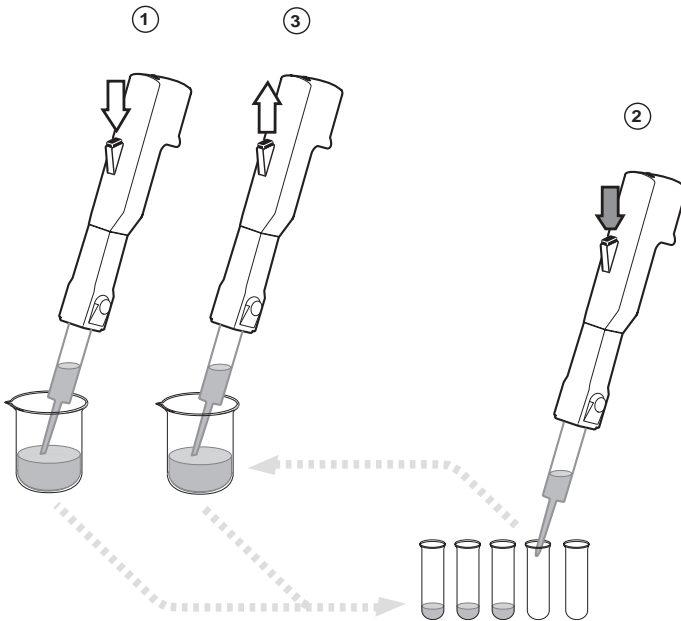

Fig. 9

- 1) Press the Start button to aspirate liquid.
- 2) Press the Start button to dispense liquid; hold down the Start button.
- 3) Immerse Combipip in the liquid and release Start button to aspirate liquid.

Note: If the Start button is not held down during dispensing, the process occurs as per Dispensing with repeat number 1.

9 Functions of the Repeater Pro

9

9.5 Speed of piston movement

Piston speed can be set separately for the upward and downward movement in five steps from 1 to 5 (5 = the most rapid movement). Speed can only be modified before liquid is aspirated, when the piston is in the Zero Position.

Key sequence



- To activate speed values for piston movement.

Display

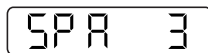

- Display of aspiration speed.



- To set the speed value.

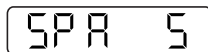

- To confirm the entry.

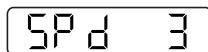

- Display of dispensing speed.

Dispensing speed is set in the same way as aspiration speed.

At top speed (Step 5), free-jet dispensing of aqueous solutions is possible using Combitips plus ≥ 2.5 mL (see also Section 10.3).

SPA = Speed aspirate

SPd = Speed dispense

9 Functions of the Repeater Pro

9.6 Stop

Stop enables aspiration of liquid to be interrupted during Functions **d** and **Ad** if insufficient liquid is available.

It is then possible for the quantity of liquid which has been aspirated into the Combitip plus up to that point to be dispensed using the preselected values. The repeat number which is possible is calculated automatically by the Repeater Pro.

Key sequence

Display

- Pressing the Start button stops piston movement during the filling motion.

- Pressing the Start button again reverses piston movement, the relaxation stroke is initiated (see Section 10.2).

- Pressing the Start button again triggers the dispensing of the relaxation stroke. The Repeater Pro is ready to dispense liquid. The partial volume and the repeat number appear in the display.

9.7 Storing and calling up the dispensing values

The Repeater Pro automatically saves two sets of dispensing values for each Combitip size when the values are entered:

- For Functions **d** and **Ad** together: the most recently entered volume, the repeat number and the time interval for **Ad**.
- For Function **P**: the most recently entered volume.

When a Combitip plus is attached, the volumes applicable for that particular Combitip are automatically available. The function last executed with the Combitip appears in the display. A set of speed values SPA/SPd is stored for each Combitip size.

Caution: Leave the Repeater Pro switched on in the stand after work has finished! If the device is switched off, the values which have been programmed are cancelled. When the device is switched back on, the programmed values are replaced by standard values.

9 Functions of the Repeater Pro

9.8 Combitip recognition

The Repeater Pro registers the size of the Combitip which has been attached only

- when the device is switched on;
- in the **Zero Position**.

If a Combitip is changed while the device is being programmed (dispensing values or speed) "**tiP**" briefly appears in the display after the values have been set. The most recently created set of dispensing values and speeds for this Combitip is then loaded.

10 Useful information

10.1 Remaining stroke

After liquid has been aspirated, a small air bubble always remains in the Combitip. This is due to the fact that the contours of the piston base never absolutely fit the contours of the cylinder, even if the piston has been pushed down fully.

This air bubble does not affect dispensing precision. However, this air bubble would cause a dispensing error if the piston were pushed down completely to the base of the cylinder and an aliquot of air instead of liquid were dispensed.

In the Repeater Pro, this is prevented by the **residual stroke lock**. The last 1/33 of the Combitip is not used as a dispensing volume. E appears in the display of the Repeater Pro and pressing the Start button has no effect, indicating that the previous dispensing step was the last one. If the Start button is pressed again, the piston moves to the basic position (**Zero Position**, see Section 7).

10.2 Relaxation stroke

After the Combitip plus has aspirated liquid, it is necessary to execute a relaxation stroke before the first dispensing. This **relaxation stroke** is executed automatically by the Repeater Pro (exception: after **StOP**, see Section 9.6).

Caution: Do not remove the Repeater Pro prematurely from the liquid during automatic execution of the relaxation stroke to avoid uncontrolled dispensing of liquid.

10.3 Free-jet dispensing

When the top dispensing speed is set, free-jet dispensing volumes (aqueous solutions) are possible using Combitips plus ≥ 2.5 mL. If smaller Combitips are used, the tip of the Combitip must be placed against the inside of the tube during dispensing. The technical data quoted (see front inner fold-back cover and Section 4) for all Combitips is tested by dispensing liquid from a tip placed against the inside of the tube.

11 Charging the Repeater Pro

11

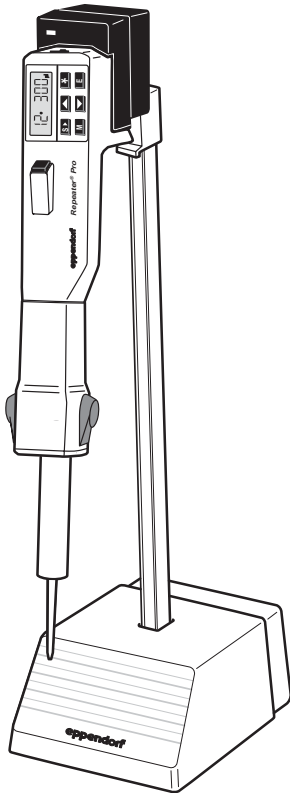

Fig. 10

11.1 Charging stand

Plug the charging stand into the mains supply using the black transformer contained in the accessories. Ensure that the voltage quoted on the transformer matches the voltage of the local mains power supply!

Hang the Repeater Pro in the charging stand, where it will be held in place magnetically. The green control lamp in the stand lights up, indicating that the charging process has begun. The charging process proceeds whether the Repeater Pro is switched on or off.

11.2 LobAt

Shortly before the battery set is completely run down, "LobAt" appears in the display. The Repeater Pro should then be recharged. The LobAt display can be skipped by pressing the E key. As a rule, one more dispensing with the whole length of the Combipip is then possible.

11.3 Battery set capacity

50 x 100 dispensings of 1/100 of a Combipip volume (aqueous solutions) may be carried out using a fully-charged Repeater Pro. If regularly placed in the charging stand after use, the device is thus always ready to use.

The power consumption of the device is very low when it is switched on, but not in use and not in the charging stand. The device should only be switched off if it is not being used for several weeks and placed in the charging stand so as to prevent total discharge of the battery.

Caution: If the device is left with a full Combipip attached for a relatively long period (piston is not in the Zero Position), it discharges more quickly. For this reason, the Repeater Pro should always be hung in the charging stand after use.

11.4 Changing the battery set

The function of the battery set is constant for approximately 1,000 charging cycles. The capacity of the battery then decreases and it should be replaced:

- Open the battery compartment in the rear of the housing by undoing the screw (screwdriver, coin).
- Remove the battery set. When inserting the new battery set, ensure that the battery contacts (in the form of a metal strip) are facing forwards/upwards (forwards = in the direction of the battery compartment - see sketch in battery compartment).

12 Maintenance and cleaning / 13 Troubleshooting

12 Maintenance and cleaning

The Repeater Pro is maintenance-free. See Section 11 for information on charging and replacing the battery set. The housing of the Repeater Pro should be cleaned using a moist cloth (diluted soap solution). Alcohol-based disinfectants may be used, but ensure that no liquid enters the device.

13 Troubleshooting

Fault	Cause	Solution
Combitip drips.	<ul style="list-style-type: none">– Combitip not attached properly (at an angle).– Combitip leaking.	<ul style="list-style-type: none">– Attach Combitip correctly.– Replace Combitip.
LobAt appears in the display.	<ul style="list-style-type: none">– Battery set needs recharging.	<ul style="list-style-type: none">– Charge Repeater Pro.
Number of dispensing steps/ charging cycle decreases, LobAt appears more often.	<ul style="list-style-type: none">– Charging capacity of battery set is decreasing.	<ul style="list-style-type: none">– Insert a new battery set. (See ordering information).
Error message in display.	<ul style="list-style-type: none">– Battery set needs recharging or electronics fault.	<ul style="list-style-type: none">– Charge Repeater Pro, switch on/off if necessary. If this is unsuccessful, contact service.
" tiP " in display	<ul style="list-style-type: none">– No Combitip attached.	<ul style="list-style-type: none">– Attach Combitip plus.

14 Ordering information

14

Ordering information

Repeater® Pro (120 V / 60 Hz), incl. charging stand	022 46 117 6
Battery set	022 46 653 4
Combitips plus standard, Minimum ordering quantity: bag of 100	
0,1 mL (beige piston)	022 26 595 4
0,2 mL (blue piston)	022 26 600 4
0,5 mL	022 26 610 1
1,0 mL	022 26 620 9
2,5 mL	022 26 630 6
5,0 mL, long	022 26 640 3
10 mL	022 26 650 1
25 mL*	022 26 655 1
50 mL*	022 26 660 8
* Adapter plus, autoclavable, required (1 pc.):	
for Combitip plus 25 mL, navy blue	022 26 699 1
for Combitip plus 50 mL, anthracite	022 26 670 5
Combitips plus assortment pack – standard (5 pcs. of each size plus one each of 50 mL and 25 mL adapter)	022 26 651 6
Eppendorf Biopur Combitips plus Individually packaged, sterile, pyrogen-free, DNA-free, RNase-free and ATP-free Minimum ordering quantity: 100	
0,1 mL (beige piston)	022 49 600 0
0,2 mL (blue piston)	022 49 602 6
0,5 mL	022 49 604 2
1,0 mL	022 49 606 9
2,5 mL	022 49 608 5
5,0 mL	022 49 610 7
10 mL	022 49 612 3
25 mL**	022 49 613 1
50 mL**	022 49 614 0
**Adapter plus Eppendorf biopur required, individually packaged (7 pcs.):	
for Combitip plus 25 mL, navy blue	022 49 615 8
for Combitip plus 50 mL, anthracite	022 49 616 6
Combitip Rack	022 26 800 7

Please only use the accessories recommended by Eppendorf. Using spare parts and disposables which we have not recommended can reduce the precision, accuracy and life of our devices. We do not honor any warranty or accept any liability for damage resulting from such action.