

Register your instrument!
www.eppendorf.com/myeppendorf



Easypet[®] 3

Operating manual

Copyright© 2016 Eppendorf AG, Germany. All rights reserved, including graphics and images. No part of this publication may be reproduced without the prior permission of the copyright owner.

Eppendorf® and the Eppendorf logo are registered trademarks of Eppendorf AG, Germany.

Easypet® is a registered trademark of Eppendorf AG, Germany.

Registered trademarks and protected trademarks are not marked in all cases with ® or ™ in this manual.

U.S. Design Patents are listed on www.eppendorf.com/ip

Table of contents

1	Operating instructions	5
1.1	Using this manual	5
1.2	Danger symbols and danger levels	5
1.2.1	Danger symbols	5
1.2.2	Danger levels	5
1.3	Symbols used	5
1.4	Glossary	6
2	Safety	7
2.1	Intended use	7
2.2	Warnings for intended use	7
2.3	Information on product liability	8
3	Product description	9
3.1	Main illustration	9
3.2	RFID chip	10
3.2.1	RFID position	10
3.3	Delivery package	10
3.4	Warranty	11
3.5	Materials	11
3.6	Features	12
4	Installation	13
4.1	Preparing installation	13
4.2	Mains/power supply device assembly	13
4.3	Removing the discharge protector	14
4.4	Rechargeable battery status display during operation	14
4.4.1	The device is ready for operation	14
4.4.2	Charging the rechargeable battery	15
4.4.3	Rechargeable battery charging	15
4.4.4	The rechargeable battery is charged	15
5	Operation	16
5.1	Loading the rechargeable battery	16
5.2	Inserting the pipette	18
5.3	Pipette types	18
5.4	Speed control	20
5.5	Aspirating liquid	21
5.6	Dispensing liquid	22
5.6.1	Flow-out	22
5.6.2	Blow-out	22

4 Table of contents
Easypet® 3
English (EN)

5.7	Using the wall mount	23
5.7.1	Mounting the wall mount	24
5.7.2	Removing the wall mount	24
5.8	Using the shelf stand.	24
6	Maintenance.	25
6.1	Disassembling the pipette clamp	25
6.2	Cleaning	25
6.2.1	Cleaning the pipetting aid	25
6.2.2	Cleaning the pipette clamp	26
6.3	Preserving the battery capacity.	27
6.3.1	Longer periods without operation.	27
6.4	Replacing the rechargeable battery	27
6.5	Mounting the pipette clamp	27
6.6	Checking the leak tightness	27
7	Troubleshooting.	28
7.1	General errors.	28
8	Technical data	29
8.1	Weight/dimensions	29
8.2	Mains/power supply device.	29
8.3	Rechargeable battery	29
8.4	Ambient conditions.	29
9	Ordering information.	30
9.1	Accessories	30
9.2	Serological pipettes.	31
10	Transport, storage and disposal	32
10.1	Decontamination before shipment	32
10.2	Transport.	32
10.3	Storage	32
10.4	Disposal.	33
	Certificates.	35

1 Operating instructions







1.1 Using this manual

- ▶ Read this operating manual completely before using the device for the first time. Also observe the instructions for use of the accessories.
- ▶ This operating manual is part of the product. Thus, it must always be easily accessible.
- ▶ Enclose this operating manual when transferring the device to third parties.
- ▶ You will find the current version of the operating manual for all available languages on our webpage under www.ependorf.com.

1.2 Danger symbols and danger levels

The safety instructions of this operating manual indicate the following danger symbols and danger levels:

1.2.1 Danger symbols

	Biohazard		Explosion
	Cuts		Toxic substances
	Hazard point		Material damage

1.2.2 Danger levels

DANGER	<i>Will</i> lead to severe injuries or death.
WARNING	<i>May</i> lead to severe injuries or death.
CAUTION	May lead to light to moderate injuries.
NOTICE	May lead to material damage.

1.3 Symbols used

Depiction	Meaning
1. 2.	Actions in the specified order
▶	Actions without a specified order
•	List
<i>Text</i>	Display text or software text
	Additional information

6 **Operating instructions**
Easypet® 3
English (EN)

1.4 Glossary

E

EIapse time

Time required to empty a pipette from the upper part of the scale to the lowest scale graduation or to fully empty a measuring pipette or volumetric pipette.

2 Safety

2.1 Intended use

The pipetting aid is intended for dispensing liquids. In-vivo applications (in or on the human body) are not allowed.

The pipetting aid may only be operated by skilled personnel who have received the appropriate training. All users must have read the operating manual carefully and must have become familiar with the device's mode of operation.

2.2 Warnings for intended use



WARNING! Damage to health due to infectious liquids and pathogenic germs.

- ▶ When handling infectious liquids and pathogenic germs, observe the national regulations, the biological security level of your laboratory, the material safety data sheets, and the manufacturer's application notes.
- ▶ Wear personal protective equipment.
- ▶ For full instructions regarding the handling of germs or biological material of risk group II or higher, please refer to the "Laboratory Biosafety Manual" (Source: World Health Organization, current edition of the Laboratory Biosafety Manual).



WARNING! Risk of explosion from potentially explosive atmospheres and potentially explosive substances.

- ▶ Do not use the Easypet 3 in potentially explosive atmospheres.
- ▶ Do not operate the Easypet 3 in areas where explosive substances are handled.
- ▶ Do not use the Easypet 3 to dispense explosive, readily flammable (flash point < 21°C), highly flammable (flash point < 0°C) or highly reactive substances.
- ▶ Do not use the Easypet 3 for dispensing substances which could generate an explosive atmosphere.



WARNING! Damage to health due to toxic, radioactive or aggressive chemicals.

- ▶ Wear personal protective equipment.
- ▶ Observe the national regulations for handling these substances.
- ▶ Observe the material safety data sheets and manufacturer's application notes.



CAUTION! Poor safety due to incorrect accessories and spare parts.

The use of accessories and spare parts other than those recommended by Eppendorf may impair the safety, functioning and precision of the device. Eppendorf cannot be held liable or accept any liability for damage resulting from the use of incorrect or non-recommended accessories and spare parts, or from the improper use of such equipment.

- ▶ Only use accessories and original spare parts recommended by Eppendorf.



CAUTION! Danger to individuals due to careless use.

- ▶ Never point the opening of a Easypet 3 which is equipped with a pipette at yourself or other persons.
- ▶ Only initiate liquid dispensing if it is safe to do so.
- ▶ With any dispensing task please ensure that you do not endanger yourself and other persons.



NOTICE! Damage to the device due to penetration of liquids.

- ▶ Do not allow any liquids to penetrate the inside of the housing.
- ▶ If liquid has entered the inside of the housing, the inner parts may only be repaired by Eppendorf AG service partners. Contact your local sales office before returning any devices.



NOTICE! Damage to device from missing pipette.

- ▶ Use the Easypet 3 only if a pipette has been inserted.



If you would like to dispense readily or highly flammable liquids, we recommend the use of a positive displacement system made up of manual Multipettes/Repeaters and Combitips. Check the resistance to chemicals and observe the safety notes before using the Multipette/Repeater.

2.3 Information on product liability

In the following cases, the designated protection of the device may be compromised. Liability for any resulting property damage or personal injury is then transferred to the operator:

- The device is not used in accordance with the operating manual.
- The device is used outside of its intended use.
- The device is used with accessories or consumables which are not recommended by Eppendorf.
- The device is maintained or repaired by people not authorized by Eppendorf.
- The user makes unauthorized changes to the device.

3 Product description
3.1 Main illustration

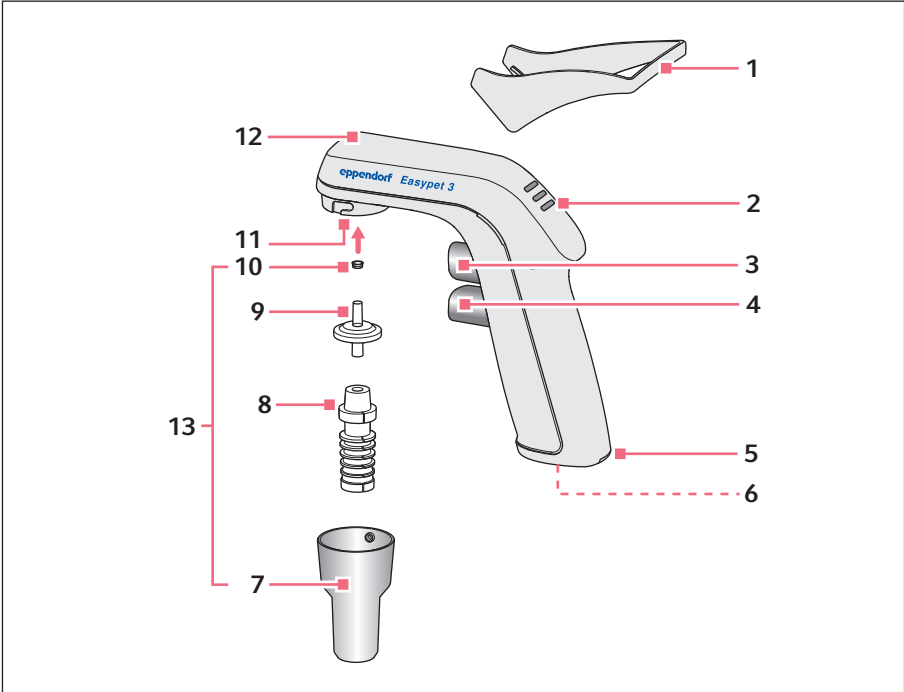

Fig. 3-1: Easypet 3 with accessories

- | | |
|--|----------------------------------|
| 1 Shelf stand | 8 Pipette adapter |
| 2 Rechargeable battery status display | 9 Membrane filter |
| 3 Aspiration button | 10 Seal for filter adapter |
| 4 Dispensing button | 11 Filter adapter |
| 5 Rechargeable battery compartment lid | 12 Pressure compensation opening |
| 6 Connector socket | 13 Pipette clamp |
| 7 Aspirating cone | |

Product description

Easypet® 3
English (EN)

3.2 RFID chip

The Eppendorf dispensing device is equipped with a RFID chip. The RFID chip can be read and written with the TrackIT reader and TrackIT software. The scanned device data is saved in a database and can be opened at any time. The device data can be exported individually or automatically in various formats.

3.2.1 RFID position

The position of the chip on dispensing devices is marked with the lettering **RFID**.

3.3 Delivery package

Quantity	Description
1	Easypet 3
1	Li-polymer rechargeable battery
2	Non-sterile membrane filter, 0.45 µm
1	Wall mount
1	Shelf stand (not available in the USA)
1	Universal power supply
1	Operating manual
1	Short operating manual
1	CD

3.4 Warranty

For warranty claims, please contact your local Eppendorf sales partner. If the housing of the pipetting aid is opened by unauthorized individuals, or the device is misused, no warranty claim may be made. The rechargeable battery and all other wear parts are excluded from the warranty.

3.5 Materials



NOTICE! Aggressive substances may damage the Easypet 3 and accessories.

- ▶ Check the resistance to chemicals before using organic solvents or aggressive chemicals.
- ▶ Only use liquids without vapors which corrode the materials used.
- ▶ Observe the cleaning instructions.
- ▶ Additional information on chemical resistance can be found on the enclosed CD or on our website www.eppendorf.com.

The pipetting aid assemblies are composed of the following materials:

Component	Material
Housing, aspirating cone, aspiration button, dispensing button, membrane filter housing, wall holder, shelf stands	Polypropylene (PP)
Filter adapter	Polybutylene terephthalate (PBT)
Pipette adapter	Silicone
Filter membrane	Polytetrafluoroethylene (PTFE)
Seal for filter adapter	Hydrated acrylonitrile butadiene rubber (HNBR)
Tubes and valves	Polymer fluorine rubber (FKM), polybutylene terephthalate (PBT), polyphenylene sulfide (PPS), silicone
Battery status display	Cyclic olefin copolymer (COC)

Product description

Easypet® 3

English (EN)

3.6 Features

The Easypet 3 is a battery-driven pipetting aid. You can use glass or plastic pipettes in a volume range of 0.1 mL to 100 mL.

A pump generates underpressure or overpressure to aspirate or dispense the liquid. The liquid can also be dispensed solely via the atmospheric pressure.

The aspirating and dispensing speed is controlled by how far the control buttons are pressed in.

4 Installation

4.1 Preparing installation

- ▶ Use the delivery package details to check that the delivery is complete.
- ▶ Check all parts for any transport damage.
- ▶ Keep the transport carton and the packing material for subsequent safe transport or storage.

4.2 Mains/power supply device assembly

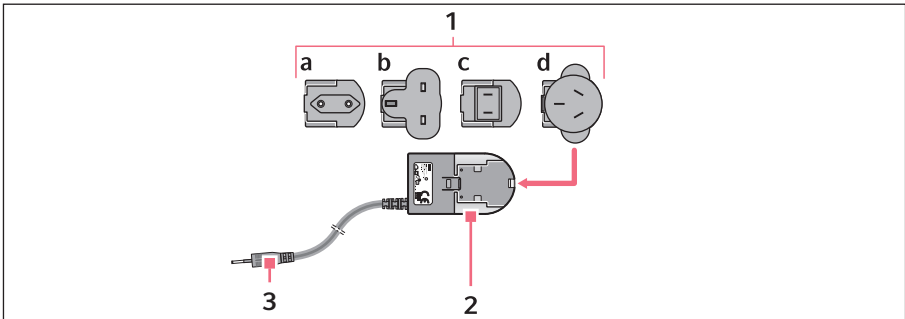

1 Power plug adapters

- a EU
- b United Kingdom
- c USA
- d Australia

3 Charging plug

2 Mains/power supply device

- ▶ Insert the power plug adapter required for your mains/power supply into the opening of the mains/power supply device. If there is any doubt as to which power plug adapter should be used for the power supply unit, you should consult an electrician.

4.3 Removing the discharge protector

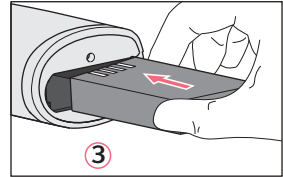
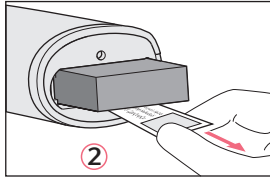
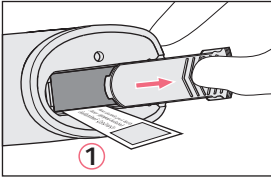

Proceed as follows:

1. Slide the battery compartment lid open.
2. Remove the battery and discharge protection.
3. Install the battery.
4. Close the battery compartment lid.

4.4 Rechargeable battery status display during operation

4.4.1 The device is ready for operation.



The rechargeable battery is fully charged.

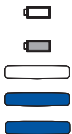

The rechargeable battery is half-charged.

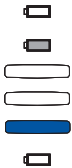

The rechargeable battery is almost empty.

4.4.2 Charging the rechargeable battery

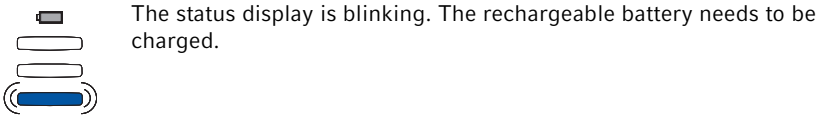

The status display is blinking. The rechargeable battery needs to be charged.



The rechargeable battery is empty and needs to be charged.

4.4.3 Rechargeable battery charging

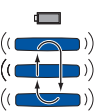

The status display blinks alternately. The rechargeable battery is being charged.

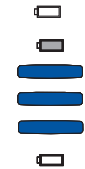

The status display lights up for approx. 30 seconds when the rechargeable battery is fully charged.

4.4.4 The rechargeable battery is charged.



If the mains/power supply device is connected to a charged rechargeable battery, the rechargeable battery status display lights up for approx. 30 seconds. The rechargeable battery will not be charged.

5 Operation

5.1 Loading the rechargeable battery



WARNING! Incorrect or damaged mains/power supply devices may lead to severe personal injury and damage to the device.

Incorrect or damaged mains/power supply devices may cause electric shock, overheat the device, set it on fire, melt it, short-circuit it or cause similar damage.

- ▶ Only the supplied mains/power supply device may be used to charge the device. You can identify the correct mains/power supply device by the Eppendorf logo and the device name on the mains/power supply device.
- ▶ Do not use damaged mains/power supply devices.



WARNING! Personal injury caused by incorrect handling of the rechargeable battery.

- ▶ Do not disassemble or modify the rechargeable battery.
- ▶ Never pierce, crush or throw the rechargeable battery.
- ▶ Only use the rechargeable battery in the supplied device.
- ▶ Do not touch a leaking rechargeable battery.
- ▶ Do not use a damaged rechargeable battery.
- ▶ Dispose of rechargeable batteries according to the legal requirements.



NOTICE! Loss of full battery charging capacity of the rechargeable battery if charged incorrectly.

The supplied rechargeable battery is not fully charged. The rechargeable battery will reach its full capacity only after several discharging and charging cycles.

- ▶ Do not charge the rechargeable battery in a hot environment (> 60 °C).
 - ▶ Only charge the rechargeable battery using the supplied mains/power supply device.
-

Proceed as follows:

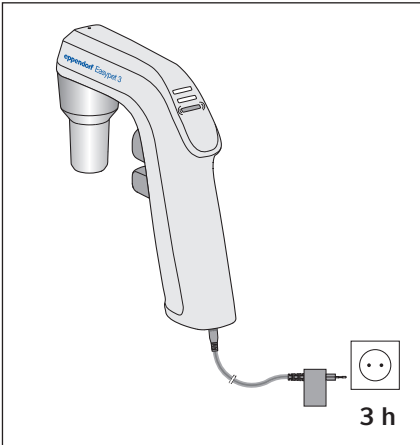

Fig. 5-1: Loading the rechargeable battery

1. Insert the mains/power supply device into the socket.
2. Insert the charging plug of the mains/power supply device into the connector socket on the grip.

- i** The charging time depends on the charging state of the rechargeable battery. For a fully discharged rechargeable battery, this is about 3 hours.
- i** You can continue using the pipetting aid during the charging process.

5.2 Inserting the pipette



WARNING! Risk of cuts from shattered glass pipettes.

Glass pipettes are fragile and may cause severe cuts if they break.

- ▶ Do not insert the glass pipettes using force.
- ▶ Wear your personal protective equipment (PPE).
- ▶ Use a towel to protect the hand used for insertion.

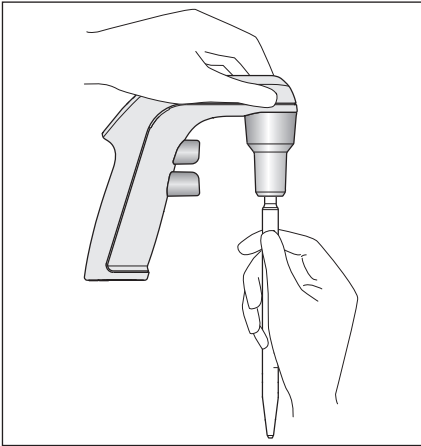

Fig. 5-2: Inserting the pipette

- ▶ Pick up the pipette from above and carefully insert it in the aspirating cone until it is positioned securely and air-tight.

5.3 Pipette types

Measuring pipettes and volumetric pipettes are divided into 3 classes: A, AS and B. Class A and AS pipettes are more precise than Class B pipettes. They vary according to the elapse time. The elapse time depends on the nominal volume and the design of the pipette. Class AS pipettes are quick-drain pipettes.

Volumetric pipettes have 1 or 2 marks and are adjusted to flow-out. Measuring pipettes have a scale and are divided into 4 types.

Type 1 measuring pipette

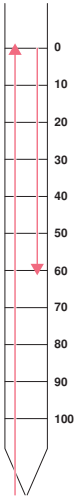

- Adjusted to flow-out.
- Nominal volume is indicated by the lowest scale graduation.
- Aspiration up to the zero line at the upper end of the pipette.
- Dispensing to any scale graduation on the scale.

Type 2 measuring pipette

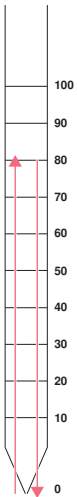

- Adjusted to flow-out.
- Nominal volume is indicated by the top scale graduation.
- Aspiration to any scale graduation on the scale.
- Dispensing until the pipette is completely empty.

Type 3 and type 4 measuring pipette

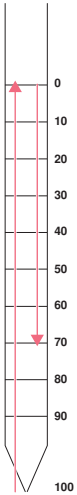

Measuring pipette

- Adjusted to flow-out.
- Nominal volume is indicated by the tip of the pipette.
- Aspiration up to the zero line at the upper end of the pipette.
- Dispensing to any scale graduation on the scale or until the pipette is completely empty.

Type 4 measuring pipette

- Adjusted to blow-out.
- Nominal volume is indicated by the tip of the pipette.
- Aspiration up to the zero line at the upper end of the pipette.
- Dispensing to any scale graduation on the scale or until the pipette is completely empty.
- Dispensing the last drops using blow-out.
- Blow-out pipettes are only available in accuracy class B.

5.4 Speed control

The liquid aspiration speed is regulated continuously by controlling how far the control button is pressed.

Slowly aspirating or dispensing liquid

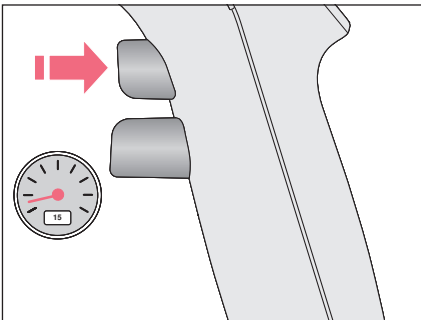

Fig. 5-3: Slow aspiration

- ▶ To slowly aspirate or dispense liquid, press the corresponding control button lightly.

Quickly aspirating or dispensing liquid

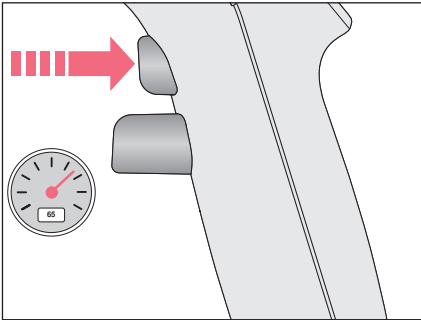

Fig. 5-4: Quick aspiration

- ▶ To quickly aspirate or dispense liquid, press the corresponding control button firmly.

5.5 Aspirating liquid



NOTICE! Damage to device due to missing or damaged membrane filter.

- ▶ Do not use the pipetting aid if the membrane filter is not inserted.
- ▶ Replace the membrane filter if it is damaged.



Observe the type of pipette used.

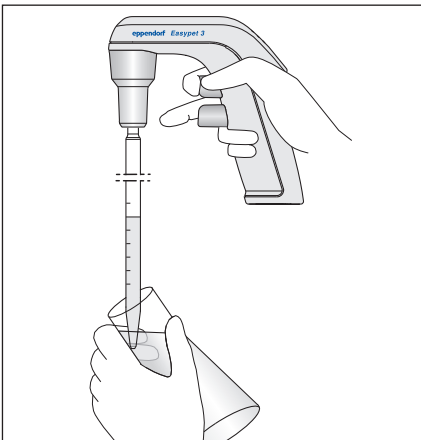

Fig. 5-5: Aspirating liquid

1. Immerse the pipette into the liquid.
2. Slowly press the aspirating button and keep it pressed down.
The further the aspirating button is pressed, the quicker the liquid will be aspirated.
3. Wipe the pipette on the tube inner wall and remove it.

5.6 Dispensing liquid

- i** Observe the type of pipette used.
- i** After liquid dispensing, hold class AS quick-drain pipettes on the tube inner wall for 5 seconds to allow the liquid to drain.

5.6.1 Flow-out

A valve will be opened during flow-out. The liquid drains from the pipette as a result of atmospheric pressure.

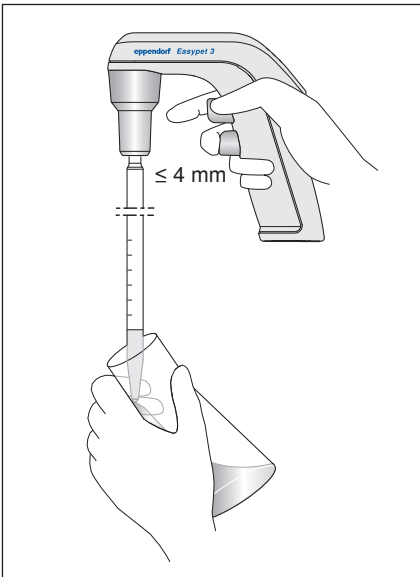

Fig. 5-6: Allowing liquid to flow-out

1. Hold the pipette vertically and place it on the tube inner wall.
2. Press the dispensing button lightly.

5.6.2 Blow-out

During blow out, the liquid will be dispensed using the pump.

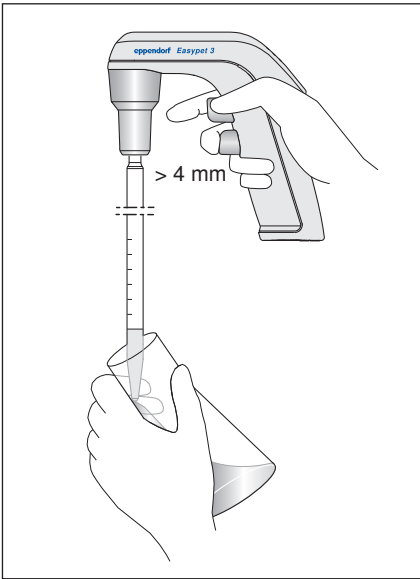

Fig. 5-7: Blowing out liquid

1. Hold the pipette vertically and place it on the tube inner wall.
2. Press the dispensing button.

5.7 Using the wall mount

For storage, the pipetting aid can be mounted in a wall mount.

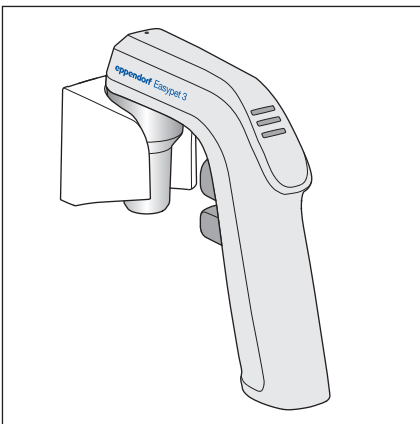

Fig. 5-8: Easypet 3 with wall mount

5.7.1 Mounting the wall mount

1. Clean the mounting location on the wall and allow it to dry.
2. Remove the protective foil.
3. Press the wall mount firmly against the wall. Allow the adhesive tape to dry for 24 hours.

5.7.2 Removing the wall mount

1. Rotate the wall mount to loosen the adhesive tape.
2. Remove the adhesive tape.

5.8 Using the shelf stand

The supplied shelf stand can also be used for storage.

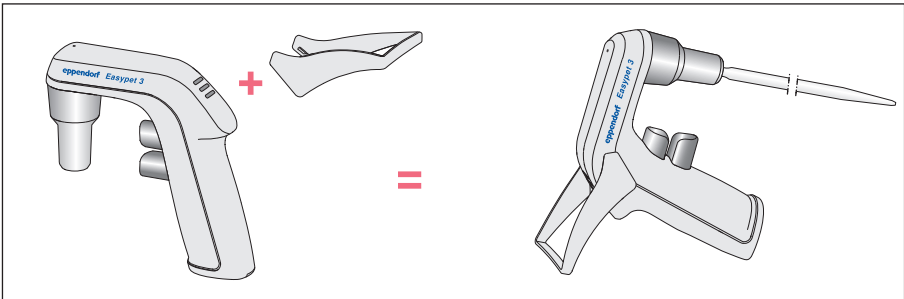

Fig. 5-9: Attaching the shelf stand

- ▶ Insert the shelf stand in the groove.
- ▶ To remove the shelf stand, press the sides of the shelf stand together.

6 Maintenance

6.1 Disassembling the pipette clamp

If liquid has entered the pipette clamp, the aspiration capacity may be decreased, or pipette clamp assemblies may be damaged. The pipette clamp must be disassembled in order to clean or replace the assemblies.

1. Turn the aspirating cone counterclockwise and remove it.
2. Remove the pipette adapter and membrane filter from the filter adapter.
3. Remove the membrane filter from the pipette adapter.
4. Use a sharp object to pry the seal out of the filter adapter.

6.2 Cleaning

6.2.1 Cleaning the pipetting aid



Special service is not required.



NOTICE! Damage to the device due to autoclaving.

- ▶ Do not autoclave the pipetting aid.

To clean contaminated surfaces, proceed as follows:

- ▶ Wipe the housing using a damp cloth.
- ▶ Disinfect surfaces using alcohol (ethanol, propanol) or alcohol-containing disinfectants.

6.2.2 Cleaning the pipette clamp

The pipette clamp assemblies can be replaced, cleaned or autoclaved as described below (121 °C, 1 bar overpressure for 20 min.)

Aspirating cone

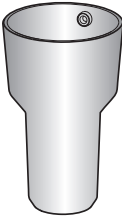

- Can be wiped using a damp cloth
- Can be disinfected with alcohol (ethanol, propanol) or alcohol-containing disinfectants.
- Repeatedly autoclavable
- Can be replaced

Pipette adapter



- Can be rinsed with demineralized water
- Repeatedly autoclavable
- Can be replaced

Membrane filter



- To be disposed of if contaminated
- Cannot be cleaned
- Can be autoclaved once
- Can be replaced

Sealing



- Can be rinsed with demineralized water
- Repeatedly autoclavable
- Can be replaced



You can also use a membrane filter with a pore size of 0.2 µm.

6.3 Preserving the battery capacity

The battery capacity can be preserved over the service life to a great extent.

6.3.1 Longer periods without operation

1. Charge the battery completely if the pipette controller is not used for a longer period of time (> 4 weeks).
2. Recharge the battery completely every 3 months.

6.4 Replacing the rechargeable battery

Proceed as follows:

1. Slide the battery compartment lid open.
2. Remove the battery.
3. Insert a new battery.

6.5 Mounting the pipette clamp

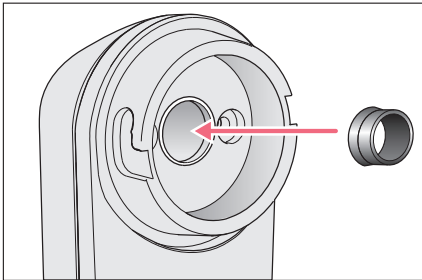

1. Push the gasket and the groove into the filter adapter.

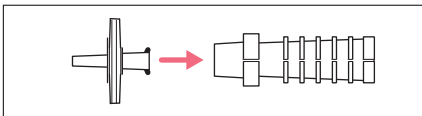

2. Push the wide opening of the membrane filter into the narrow opening of the pipette adapter.
3. Guide the aspirating cone over the pipette adapter and turn it until it engages.

6.6 Checking the leak tightness

1. Insert the pipette.
2. Fill the pipette with water.
3. Hold the pipette vertically.
4. Observe the pipette outlet for approx. 30 seconds.

i Do not touch the pipette. Do not press the control buttons.

No water may be allowed to escape.

5. If water escapes, disassemble, and carefully reassemble, the pipette clamp.

7 Troubleshooting

7.1 General errors

Symptom/message	Cause	Remedy
Liquid drips out of the pipette.	• Pipette adapter and/or membrane filter inserted incorrectly.	▶ Remove the pipette adapter and membrane filter and reinsert them.
	• Pipette not inserted far enough.	▶ Continue to carefully insert the pipette.
	• Pipette adapter damaged.	▶ Replace pipette adapter.
	• Pipette damaged.	▶ Replace pipette.
	• Seal damaged.	▶ Replace seal.
	• Liquid column too high. • Speed too low.	▶ Slowly press the aspirating button down further.
Aspiration capacity reduced.	• Membrane filter wetted.	▶ Replace membrane filter.
No functional period despite fully charged battery.	• Battery is too old.	▶ Replace battery.
Pipette loose.	• Pipette adapter damaged.	▶ Replace pipette adapter.
Bubble formation in the pipette during liquid aspiration.	• Too high speed.	▶ The aspirating button may only be pressed lightly.
	• Too high speed.	▶ The aspirating button may only be pressed lightly.
Rechargeable battery will not charge.	• Rechargeable battery is charged.	▶ Disconnect the mains/power supply device. ▶ Only charge the rechargeable battery if the status display is blinking.

8 Technical data

8.1 Weight/dimensions

Weight	134 g (0.295 lb) (without rechargeable battery, without pipette)
--------	--

8.2 Mains/power supply device

Input voltage	100 V – 240 V AC, $\pm 10\%$
Frequency	50 Hz – 60 Hz
Output voltage	5 V
Input current	200 mA – 250 mA
Output current	1 A

8.3 Rechargeable battery

Type	Lithium-Polymer
Voltage	3.7 V
Capacity	1100 mAh
Charging time	~3 h
Weight	26 g (0.057 lb)
Number of dispensings	~2000 (with a 25-mL pipette)

8.4 Ambient conditions

Ambience	For indoor use only.
Ambient temperature	5 °C – 40 °C
Relative humidity	10 % – 95 %, non-condensing
Atmospheric pressure	79.5 kPa – 106 kPa

Ordering informationEasypet® 3
English (EN)**9 Ordering information**

Order no. (International)	Order no. (North America)	Description
4430 000.018		Easypet 3 Incl. power supply, wall mount, depositing stand, 2 membrane filters (unsterile) 0.45 µm
	4430000026	Easypet 3 Incl. power supply, wall mount, 2 membrane filters (unsterile) 0.45 µm

9.1 Accessories

Order no. (International)	Order no. (North America)	Description
4420 801.004	022236105	Pipette adapter
		Membrane filter sterile, 1 set (5 pieces)
4421 601.009	022232002	0.45 µm
4430 606.005	4430606005	0.2 µm
4421 602.005	4421602005	Seal for filter adapter 5 pieces
4430 601.003	4430601003	Aspirating cone
4430 602.000	4430602000	Rechargeable battery compartment lid
4430 603.006	–	Shelf stand
4430 604.002	4430604002	Wall mount
		Lithium polymer rechargeable battery For Eppendorf Easypet 3
4430 605.009	4430605009	
4430 607.001	4430607001	Sticky tape 2 pieces
4986 603.005	4986603005	Power supply with power plug adapters for Xplorer/Xplorer plus, Multipette/Repeater (X) stream

9.2 Serological pipettes

Order no. (International)	Order no. (North America)	Description
0030 127.692	0030127692	Eppendorf Serological Pipet, 1 mL 4 boxes of 200 (800 pieces)
0030 127.706	0030127706	Eppendorf Serological Pipet, 2 mL 4 boxes of 150 (600 pieces)
0030 127.714	0030127714	Eppendorf Serological Pipet, 5 mL 4 boxes of 100 (400 pieces)
0030 127.722	0030127722	Eppendorf Serological Pipet, 10 mL 4 boxes of 100 (400 pieces)
0030 127.730	0030127730	Eppendorf Serological Pipet, 25 mL 4 boxes of 50 (200 pieces)
0030 127.749	0030127749	Eppendorf Serological Pipet, 50 mL 4 boxes of 40 (160 pieces)

10 Transport, storage and disposal**10.1 Decontamination before shipment**

Before sending the pipetting aid to the authorized Technical Service for repairs, or to your authorized dealer for disposal, you must decontaminate the pipette. Please note the following:

10.2 Transport

- ▶ Use the original packaging for transport.

	Air temperature	Relative humidity	Atmospheric pressure
General transport	-25 °C – 60 °C	10 % – 95 %	30 kPa – 106 kPa
Air freight	-40 °C – 45 °C	10 % – 95 %	30 kPa – 106 kPa

10.3 Storage

	Air temperature	Relative humidity	Atmospheric pressure
In transport packaging	-25 °C – 55 °C	10 % – 95 %	70 kPa – 106 kPa
Without transport packaging	-5 °C – 45 °C	10 % – 95 %	70 kPa – 106 kPa

10.4 Disposal

In case the product is to be disposed of, the relevant legal regulations are to be observed.

Information on the disposal of electrical and electronic devices in the European Community:

Within the European Community, the disposal of electrical devices is regulated by national regulations based on EU Directive 2002/96/EC pertaining to waste electrical and electronic equipment (WEEE).

According to these regulations, any devices supplied after August 13, 2005, in the business-to-business sphere, to which this product is assigned, may no longer be disposed of in municipal or domestic waste. They are marked with the following symbol to indicate this:

As disposal regulations may differ from country to country within the EU, please contact your supplier if necessary.



WARNING! Risk of explosion and fire due to overheated rechargeable batteries and batteries.

- ▶ Do not heat rechargeable batteries and batteries to over 80 °C and do not throw them into fire.

Disposing of accumulators and batteries

Do not dispose of accumulators and batteries as household waste. Dispose of accumulators and batteries according to the locally applicable legal regulations.



Declaration of Conformity

The product named below fulfills the requirements of directives and standards listed. In the case of unauthorized modifications to the product or an unintended use this declaration becomes invalid.

Product name:

Easypet® 3

including charging adapter

Product type:

Electric pipette controller

Relevant directives / standards:

2014/35/EU EN 61010- 1

2014/30/EU EN 55011/B, EN 61326- 1

2011/65/EU EN 50581

Date: February 23, 2016



Management Board



Portfolio Management

Your local distributor: www.eppendorf.com/contact
Eppendorf AG · 22331 Hamburg · Germany
eppendorf@eppendorf.com

Eppendorf® and the Eppendorf logo are registered trademarks of Eppendorf AG, Germany.
U.S. Design Patents are listed on www.eppendorf.com/ip.
All rights reserved, incl. graphics and pictures. Copyright 2015 © by Eppendorf AG.

www.eppendorf.comISO 9001
CertifiedISO
13485
CertifiedISO
14001
Certified

Evaluate your manual

Give us your feedback.
www.eppendorf.com/manualfeedback

Your local distributor: www.eppendorf.com/contact
Eppendorf AG · 22331 Hamburg · Germany
eppendorf@eppendorf.com · www.eppendorf.com